

**Whozz Calling?
Lite Series
Caller ID
Interface Unit**



User Interface Guide
for
Whozz Calling? Lite Series
4 and 8 Line Units

Whozz Calling? Lite User's Guide

(Version 3.0 10/17/03)

Introduction

The Whozz Calling? Lite reports telephone line number and Caller ID information. Caller ID information consists of date, time, caller's number and caller's name (if sent). This information is sent via serial stream to any serial device such as a printer or a computer immediately after Caller ID data is captured. Data can be sent at either 9600 or 1200 Baud. Three different formats are available. The CallerID.com format conforms with all other Whozz Calling? products. The Comdial format works with Caller ID compatible Comdial switches. The limited format matches the TCI, MLX series format. Input and output RJ14 jacks are provided to connect the unit in series with the CO phone lines, but it will **also** operate when connected in parallel. The first ring suppression feature can be used only if the unit is connected in series. If multiple units are to be connected together, each individual unit can be set for different line numbers. All options, formats, and addresses are set using DIP switches located on the front panel of the unit.

Telephone Line and Serial Communication Requirements

The monitoring unit is designed to collect call data from standard telephone lines (trunk or CO lines) coming into your building. It will not work properly if connected to extensions (or station) lines coming from a telephone switch. Connect the unit only to analog loop start, ground start, or Centrex™ phone lines. It is not designed for ISDN, T1, T3, E1, E3, DID, or Digital Centrex type phone lines

The unit can be connected to a printer or to a computer through a serial port. A serial printer connects using a null modem adapter or null modem cable. A parallel printer requires a serial to parallel converter as well as a null modem adapter. If connected to a computer, the serial port must be free of COM Port and IRQ conflicts and dedicated to the monitoring unit. The unit can work with any serial port regardless of the COM number and/or IRQ it is using.

Quick Start Procedure

In order to see Caller ID information on your computer, you will need some type of serial communications program such as Windows Terminal or Hyper-Terminal, PC Plus, Bitcomm, Cross Talk, PC Anywhere, etc. Follow the instructions below for connecting to your computer and refer to Fig. 1.

1. Connect the supplied 9 pin cable to the female serial connector on unit marked "To Computer".
2. Connect this same cable to an available serial port on the computer.
3. Plug in up to four, 4-wire RJ14 phone lines into the input jacks marked "IN" on the unit.
4. Use any terminal emulation program or modem software set to terminal mode.
5. Set communication parameters to 9600 Baud, 8 Bit, 1 Stop, No Parity.
6. Plug in the power supply and make sure the red channel LEDs light.*
7. Make a phone call to one of the lines connected to the unit. The Caller ID information will appear on your screen.

* The power up sequence of the unit will flash the LEDs and click each relay sequentially. The unit will send the firmware version number of each channel to the serial port when the DIP switches are positioned to send the CallerID.com format (Fig. 2a).

Fig. 1 Front and Back Views of 8 Line Model

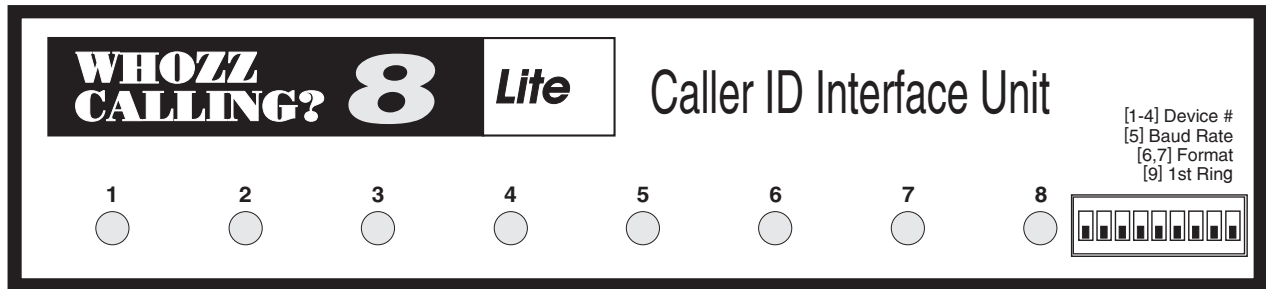

A few seconds after power-up, LEDs will flash in sequence and relays will click. The LEDs will then remain on.

DIP Switch Controls
 #1-4 set unit line numbers when 2 or more units are connected together
 #5 sets baud rate (OFF=9600, ON=1200)
 #6 & #7 sets format (#6 & #7 OFF for Zeus)
 #8 set OFF (8 line model) or ON (4 line model)
 #9 set ON for first ring suppression

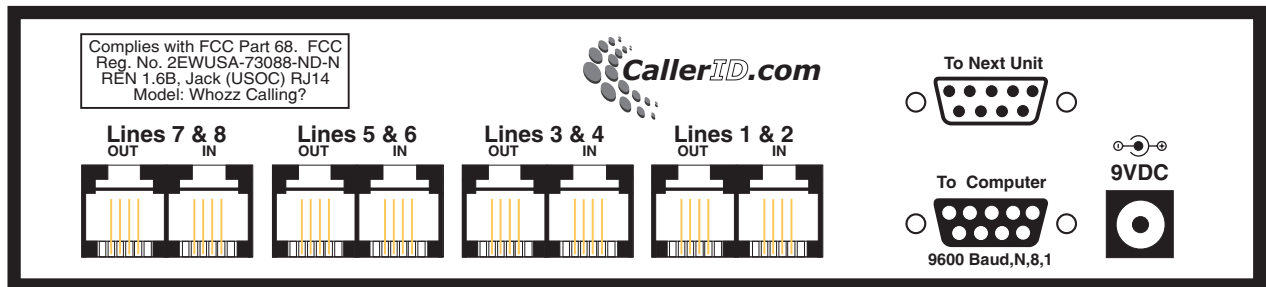

4 conductor jacks connect to two phone lines using both pair of wires on cord.
 IN from Telephone Co.
 OUT to phones or phone switch (Optional).

Standard RS232
 1200 or 9600 Baud.
 (Default is 9600 Baud).
 8 Bit, 1 Stop, No Parity.
 Top jack connects to bottom jack of additional unit.

Power Jack
 (9 VDC
 Center Negative)

Dip Switch Settings

INDIVIDUAL UNIT ADDRESSING - SWITCHES 1-4

As many as 12 individual units can be connected together to monitor up to 96 phone lines. Each unit should be configured to report data with appropriate lines numbers. The first field in the data stream indicates the phone line for the subsequent Caller ID data transmitted. DIP switches 1-4 determine the phone line number that each unit reports. Refer to the table below to set each unit.

Address		DIP Switch #			
Unit #	Lines	1	2	3	4
1	1-8	-	-	-	-
2	9-16	ON	-	-	-
3	17-24	-	ON	-	-
4	25-32	ON	ON	-	-
5	33-40	-	-	ON	-
6	41-48	ON	-	ON	-
7	49-56	-	ON	ON	-
8	57-64	ON	ON	ON	-
9	65-72	-	-	-	ON
10	73-80	ON	-	-	ON
11	81-88	-	ON	-	ON
12	89-96	ON	ON	-	ON

Use the supplied serial cable to connect unit #1 with unit #2, unit #2 with unit #3, etc. The cable attaches to the unit #1 port marked "To Next Unit" to the unit #2 port marked "To Computer." Unit #2 connects with unit #3 in the same manor.

CONNECTING 4 LINE MODELS TOGETHER

When connecting multiple Whozz Calling? Lite 4 line models together set DIP switch #8 to ON. The DIP switches 1-4, used to set the correct line numbers for each unit, will increment line numbers by 4 instead of 8. For example, the first 4 line model would have DIP switch #8 ON (1,2,3,4 OFF) to set it for line numbers 1 through 4. The second unit would have #8 and #1 ON (2,3,4 OFF) for lines 5 through 9.

Model	DIP Switch #8
8 line	-
4 line	ON

BAUD RATE SETTING

The unit can be set to deliver data to the serial port at either 9600 or 1200 Baud. The DIP switch number 5 controls this setting. Refer to the table below:

Baud Rate	DIP Switch #5
9600	-
1200	ON

Fig. 2a CallerID.com Format

(DIP Switch #6 & #7 set OFF)

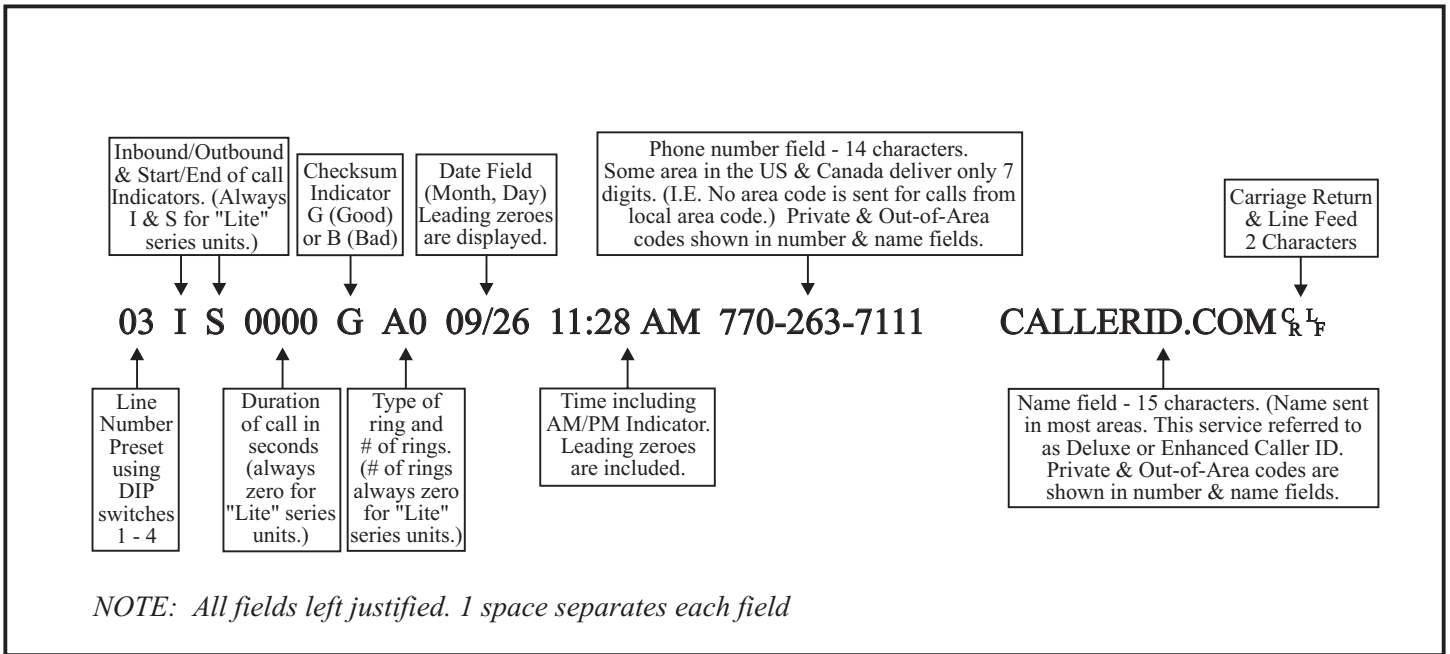
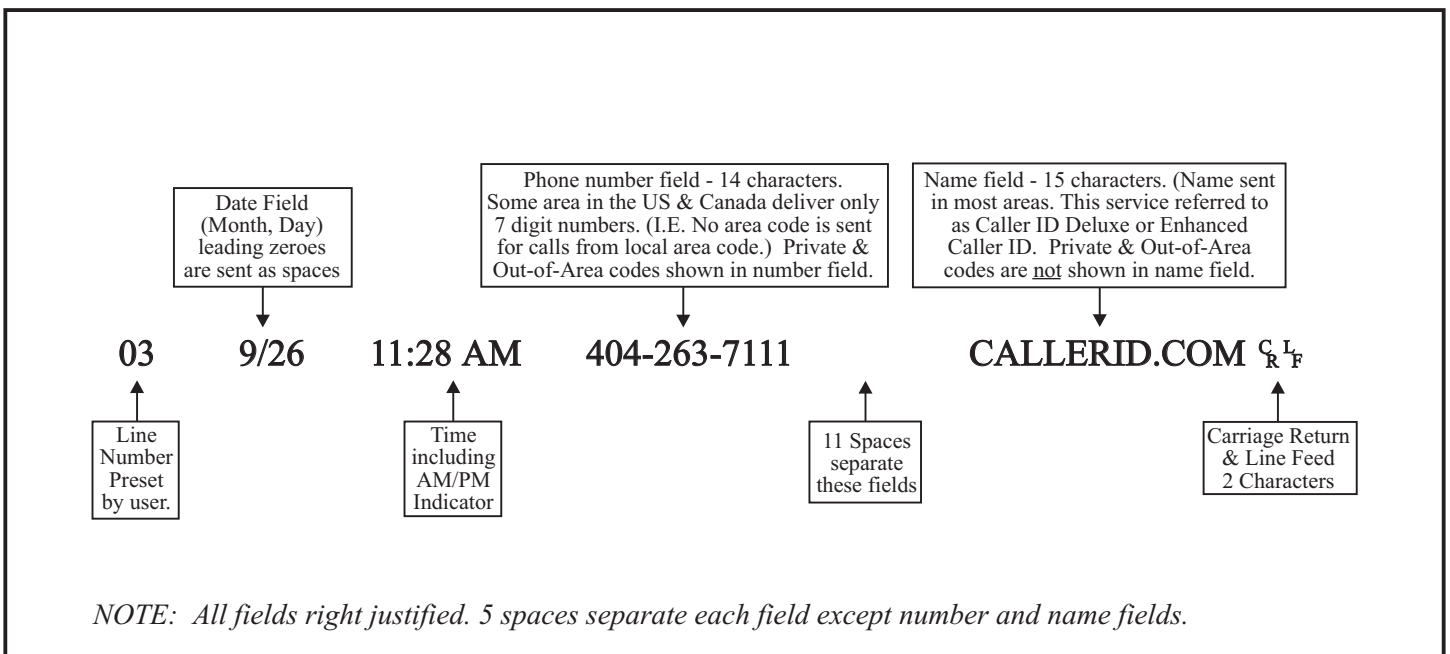

Fig. 2b TCI Format

(DIP switch #6 set OFF, #7 set ON)



FORMAT SETTING

The unit can deliver either the CallerID.com Whozz Calling? format, the TCI format, or the Comdial Caller ID capable Key Switch format. DIP switch numbers 6 and 7 control the unit out format. Refer to the table below and to Fig. 2:

<u>Format</u>	<u>#6</u>	<u>#7</u>
CallerID.com	-	-
TCI	-	ON
Comdial	ON	ON

The CallerID.com format is recommended since it is one of the industry standards. This format is used with all other CallerID.com products with serial output. Several software vendors have adopted this standard since it gives them the flexibility to handle any type of call accounting application. The CallerID.com format provides additional fields for outbound digits dialed, inbound digits dialed after answer, number of rings before answer, call duration, and type of distinctive ring pattern. The Standard Whozz Calling? reports this additional phone call information. Even if your present application does not require this additional information, we still recommend using the CallerID.com format so that future applications may be converted to read the additional data. Please refer to Fig. 2a for the exact format specifications.

Note that the Comdial format is provided on the Lite series units for interfacing with Comdial DSU, Comdial DXP and Unisyn Key Switches. For more information please refer to Appendix A.

FIRST RING SUPPRESSION

First ring suppression is used in cases where the phone may be answered before the Caller ID signal is sent by the phone company. If the unit is connected in series with the CO phone lines, it is capable of suppressing the first ring to the phones at the location. Suppression of the first ring allows the phones to ring only after Caller ID has been captured. This is necessary when a device connected to the phone line answers on the first ring as with some alarm monitoring panels, automated attendants, and voice mail systems. First ring suppression is also important when the unit is used in conjunction with a Key Switch or PBX since the switch ring down to extension lines does not track the ring cadence from the CO. First ring suppression is controlled by DIP switch #9. Refer to the table below.

<u>Suppress 1st Ring</u>	<u>DIP Switch #9</u>
No	-
Yes	ON

Serial Connections and Phone Connections

The supplied six foot, 9 pin serial cable connects the unit to a serial equipped device such a printer or computer. If your printer or computer has a 25 pin serial port, a 9 to 25 pin adapter is recommended. If connected directly to a serial printer a null modem adapter will be required. These adapters are available at any computer or Radio Shack™ store. Additional monitoring units are connected to one another using the supplied 9 pin cable. Please refer to page 3 for more information on connecting multiple units.

Phone lines are connected to the back of the unit using modular jacks. Input and output ports are provided for wiring systems using 4 wire RJ14 connections. If the wiring coming into your building does not terminate in modular RJ14 jacks, contact your telephone vendor to add these modular connections.

CONNECTING DIRECTLY TO A PRINTER

Printers have either a serial or parallel input. Most newer printers use parallel connections. A parallel printer will require a separate serial-to-parallel converter unit.

A null modem adapter or cable must be used when connecting a printer directly to the unit. The monitoring unit sends information out on pin 2 while a serial printer or serial-to-parallel converter receives information on pin 3. The null modem adapter reverses the transmit and receive pins by connecting pin 2 to pin 3 and pin 3 to pin 2. (The null modem adapter is not required on a computer serial port which receives information on pin 2.)

A 9-25 pin adapter may also be required and is available at any computer or Radio Shack™ store.

Serial printers are available from only a few manufacturers. Okidata Corporation carries at least 2 different models. Ask for Model 590 with serial option or Model 395 with serial option.

Set your printer to **9600** Baud, **8** Data Bits, **1** Stop Bit, **No** Parity. The unit sends both Carriage Return and Line Feed commands, so the printer should be set to **No** Automatic Line Feed.

CONNECTING TO COMPUTER

You may have purchased a software package designed to work in conjunction with the Whozz Calling? unit. The software may have a built-in automatic search and find function. This routine will search all COM and IRQ numbers in an attempt to determine settings for the serial port to which the unit is connected. If an error message indicates that the software cannot communicate or “find” the unit, you will need to run the Loopback Test below to determine if there exists communication port conflicts within your computer. If your software requires a manual selection of the COM and/or IRQ settings, the Loopback Test is also helpful in determining these parameters.

The unit should be connected to the serial port, placed in a convenient location next to the computer, and your software installed. Permanent installation and phone line connections can be made once communications between the software and hardware is established. Plug in the power to the unit and run the software. Phone lines need not be connected at this time. The software will either communicate with the unit connected to the computer or display a message indicating no communication.

If a no communication error is indicated and your software has an automatic search function, it has tried to communicate with the unit using every combination of COM and IRQ numbers. The serial port is probably not configured correctly and chances are the COM port number and/or IRQ number defined for the serial port conflicts with another device such as an internal FAX/ modem. If an auto-search function is not performed within the software, the COM and/or IRQ numbers must be set manually. Enter different combinations of COM and/or IRQ numbers to establish communication. If unsuccessful, use the Loopback Test to help determine whether communication conflicts reside in your computer.

To determine whether a serial port is configured and working properly use the Terminal program in Windows 3.x or HyperTerminal in Windows 95 and Loopback test procedure on the following page.

Loopback Test for a Serial Port Connection in Windows

1. Make sure your software program that runs in conjunction with Whozz Calling? is closed.
2. Run **HyperTerminal** from the Accessories Program Group.
3. In the Connection Description dialog box Type: "**Test**" on the Name line and Select: **OK**
4. In the Phone Number dialog box leave phone number blank and Select: Connect using **Direct to COMx**. Where "x" represents the COM port number being tested (ex. 1,2,3, etc.) Select: **OK**
5. In the Properties dialog box Select Bits per second: **9600**, Data bits: **8**, Parity: **None**, Stop bits: **1**, and Flow Control: **None**. Then Select: **OK**
6. Select: **File/Properties**. In the Test Properties dialog box select the **Settings** tab and set Emulation to **ANSI**. Select **ASCII Setup** and make sure that Echo typed characters locally box is not checked. Select: **OK** to close and **OK** again to close the Test Properties box.
7. Disconnect the serial cable from the unit, and attach the supplied Loopback Connector to the cable (the other end is connected to the serial port on the PC).
8. Type any character.
 - a. If the character you typed shows on the screen, the serial port is functioning properly, the test is positive.
 - b. If you do not see the character COM port and click **OK**.
 - c. Select: **Call/Connect** and type any character again and repeat above as necessary.
9. If you obtain a positive result, close HyperTerminal and run the your software again. If not, you may have a conflict between your serial port settings and an internal device such as a FAX/modem. Consult your computer technician to resolve the conflict.

CONNECTING TO PHONE LINES

There are two basic methods of connecting the monitoring unit to your phone lines: the series (pass through) connection, or the parallel (branch off) connection. The series connection uses both input and output modular jacks on the unit. The parallel connection uses only the input jacks.

Series Connection

Connecting the unit in series allows the use of the first ring suppression feature. Since the Caller ID signal is sent on the telephone line between the first and second ring, suppressing the first ring will prevent the call from being answered before the Caller ID data is sent. A series connection allows the user to have the option of suppressing the first ring simply by setting DIP switch 9 ON (refer to page 5).

Figure 3a shows series connections. Each phone line to be monitored passes through the unit. Phone lines coming into the building connect to the input jacks on the unit (through bare wire to modular adapters, if needed). Lines connected to the output jacks continue to the desktop phones (through a phone switch, if present).

Parallel Connection

A parallel phone line connection is often easier since the incoming lines to the building need only "branched off" to the unit. The unit can monitor the telephone activity simply by being connected to the phone lines of interest. With this connection only the input ports on the unit are used.

Figure 3b shows parallel connections. This involves branching off or "tapping" from each phone line to be monitored and connecting them to their respective input jacks on the unit (through bare wire to modular adapters, if needed). As mentioned above, this method of connection does not provide for first ring suppression capability.

4-Wire (RJ14) Phone Cord Connections.

Most modular phone cords contain 4 wires which can supply two phone lines (2 wires for each line.) Your system may have either 2 of the wires connected (RJ11 - 1 phone line) or four wires connected (RJ14 - 2 phone lines). The modular connectors on the unit are equipped to handle only 4-wire RJ14 connections. They are marked similar to the modular connectors on a 2 line phone. For example, Jack 1 is marked "L1/L2" and connects 1 phone cord supplying 2 phone lines (RJ14). Refer to Fig. 1.

2-wire (RJ11) systems can be converted to 4-wire RJ14 systems in a number of ways. Check with your telephone vendor or local Radio Shack™ store for available adapters.

MOUNTING HARDWARE

A 1 inch wide black plastic mounting bracket is used to attach the unit to a wall or phone board. Remove the two Phillips head screws on the bottom of the enclosure and attach the bracket to the unit with the same screws. Mount on wall using appropriate hardware.

Fig. 3a Series Connection

Lines coming into the building from the telephone company are connected to the input jacks on the monitoring unit. If these lines do not terminate in modular connectors, solid wire to modular adapters need to be installed. The output lines from the unit go to the desktop phones. If a telephone switch is present, they connect through the switch first.

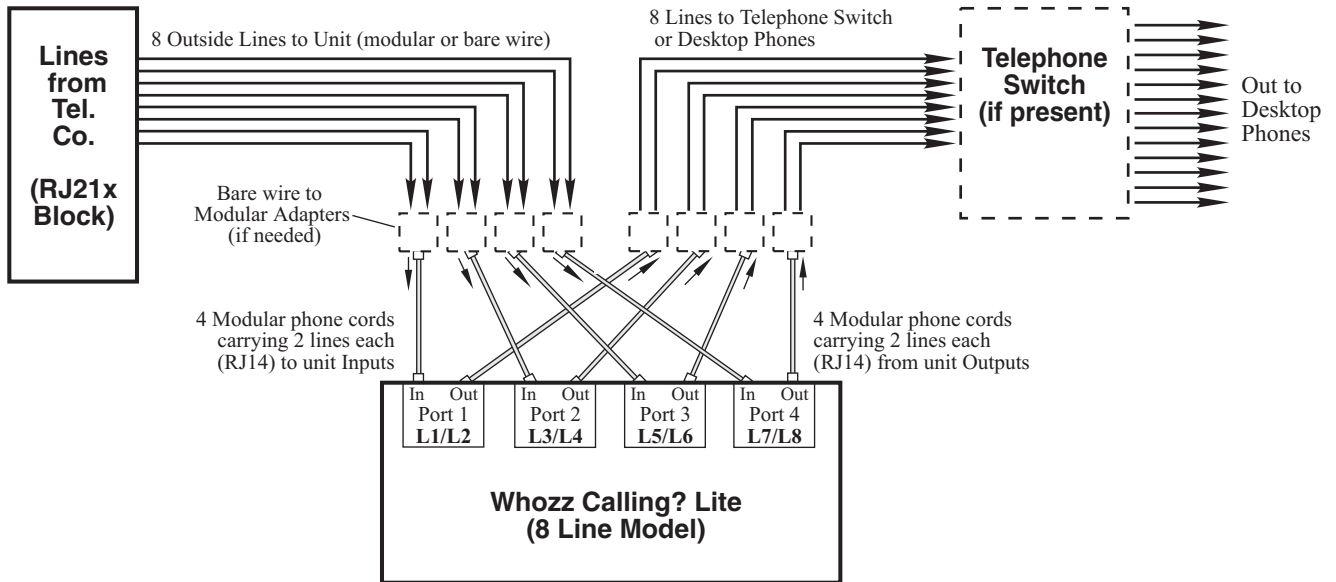
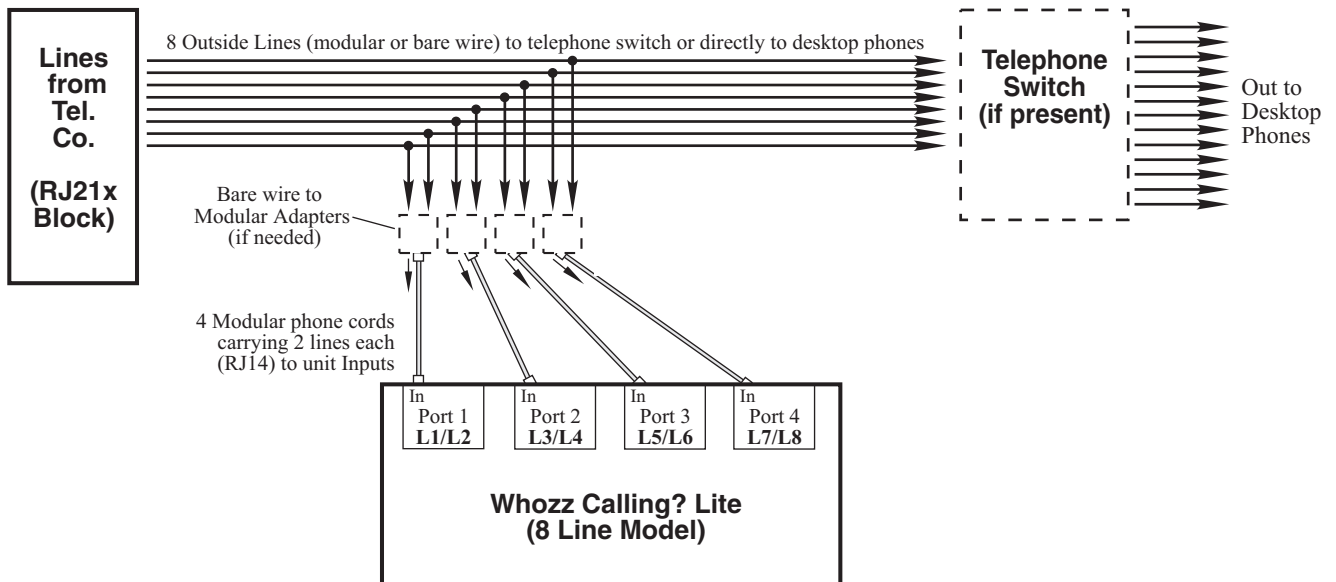

Fig. 3b Parallel Connection

Lines coming into the building from the telephone company are connected to the telephone switch or directly to desktop phones. These lines are branched (or tapped) so that they can be connected to the input jacks of the monitoring unit. If these lines are not modular, solid wire to modular adapters need to be installed. The output lines on the unit are not connected.



Specifications

Supply Voltage:	9 VDC, center negative
Supply Current:	Less than 250 mA
Loop Current Draw:	Less than 1 mA
Loop Voltage:	30 to 105 VDC
Ringing Voltage:	60 to 130 VAC
Insertion Loss:	Less than 0.3 dB
Voltage Drop:	2.7 VDC at 20 mA loop current
Dimensions:	4.3" x 3.25" x 1.5"
Ringer Equivalence:	(REN) 0.1 B

Manufacture's Information

CallerID.com
3107-D Medlock Bridge Road
Norcross, GA 30071

Sales	(800) 240-4637
Customer Service	(770) 263-7111
FAX	(770) 263-0049

Web Site www.callerid.com

Warranty Information

CallerID.com will repair this product with new or rebuilt parts, free of charge, when returned shipping prepaid to the CallerID.com repair facility in Norcross, GA within 6 months from the date of original purchase.

This warranty is extended only to the original purchaser. A purchase receipt or other acceptable proof of purchase date will be required before warranty service is rendered.

This warranty covers failures due only to defects in materials or workmanship occurring during normal use. It does not cover damage which occurs in shipment; failures which are caused by products not manufactured by CallerID.com; failures which result from accident, misuse, abuse, neglect, mishandling, misapplication, alteration, modification or unintended use of product; service by anyone other than an authorized CallerID.com repair facility; or damage attributed to an act of God. Lightning is considered an act of God. CallerID.com makes no other warranty, either expressed or implied, with respect to this product.

If a problem develops concerning this product, contact CallerID.com directly for a Return Material Authorization (RMA).

FCC Information

This unit is designed to conform to federal regulations and complies with Part 68 of the FCC rules. On the back of this equipment is a label that contains the FCC registration number and ringer equivalence number (REN) for this equipment. Upon request, you may have to provide the FCC registration number and the REN to your telephone company.

The ringer equivalence number (REN) is used to determine how many devices can be connected to your telephone line. In most areas, the sum of the RENs on any one line should not exceed 5. If too many devices are attached, your phones may not ring properly and other devices on the line may not detect the ring signal.

In the most unlikely event that your unit causes significant problems on the telephone line, the telephone company can disconnect your service. The telephone company will attempt to notify you in advance and will advise you of your right to file a complaint with the FCC. The telephone company may make changes in its technical operation and procedures that may affect the operation of this device. The telephone company is required to give adequate notice of such changes. This product should not be connected to coin operated or party line systems.

Appendix A - Connections for Comdial Caller ID Capable Switches

Three types of Comdial switches support Caller ID input from external hardware. Models include: Unisyn, Comdial DSU and Comdial DXP. The Whozz Calling? - Lite series uses a standard Female 9 pin RS232 connector for output of data to a serial port on Comdial Caller ID capable equipment. Only 2 of the 9 pins are used: Pin 2 is for data output and Pin 5 is for signal ground. The data transmission parameters are 9600 Baud, 8 bits, 1 stop bit, no parity.

UNISYN CONNECTIONS

Optional serial ports are available with this Comdial model and must be present to support Caller ID from the Whozz Calling? unit. The Comdial "B" port (DB9 male) is used to connect to the Whozz Calling? output port (DB9 female). Since all pins on a standard serial cable are connected one for one, a standard serial cable can be used only if it is connected in series with a null modem adapter. A null modem adapter reverses the transmit and receive pins 2 and 3. Please refer to the diagram below for the correct pin connections.

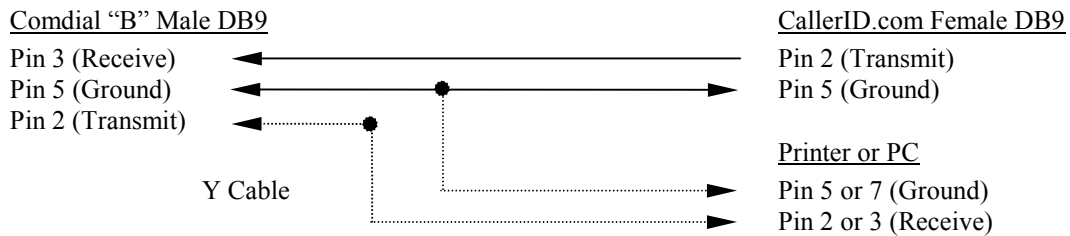

Fig A1

Pins 1,4,6,7,8, and 9 are not connected on the 9 Pin Cable. A "Y" cable should be used if SMDR output from the switch is also to be monitored with a printer or PC. The output connection to the printer or PC uses Pin 5 for ground on a DB9 or Pin 7 on a DB25. (Note that a DB9 to DB25 adapter connects Pin 5 on the 9 pin side with 7 on the 25 pin side). The receive pin will either be Pin 2 or 3 depending on whether a printer or PC is installed and whether a 9 pin or 25 pin connector is used.

DSU CONNECTIONS

This digital system is available in 4x8, 8x16, and 16x32 configurations. The serial data ports on the 4x8 and the 8x16 are connected via a 25 pair punch block. The Caller ID connection uses Port B on the Comdial unit. Please refer to the diagram below.

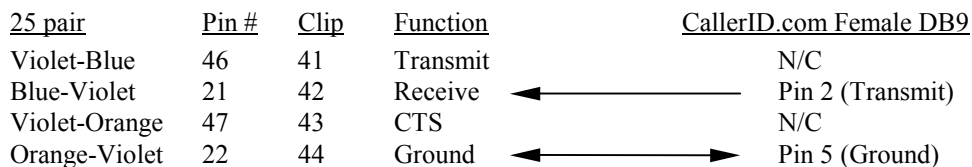
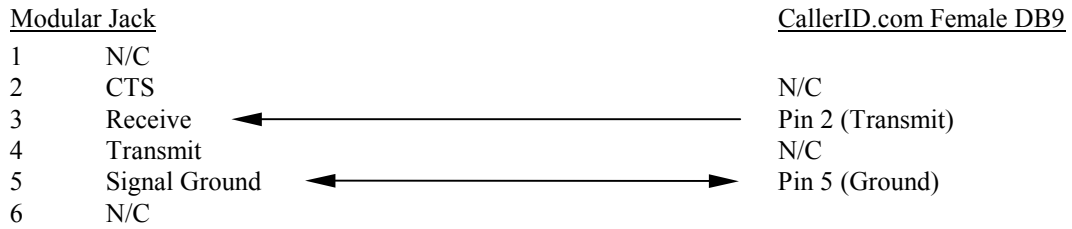

Fig. A2

The 16x32 (upgradeable to 24x48) system uses a 6 pin, RJ14, modular jack for serial connection.



The modular jack is numbered with Pin 1 on the right and Pin 6 on the left as viewed from the front of the jack with the notch for the clip on top.

Fig. A3

Both of the above two DSU systems use Port B for Caller ID data input. If SMDR output from the switch is to be monitored, a “Y” cable must be used. Transmit from the switch connects to receive on the printer or PC and the ground line is be connected. See Fig A1 on previous page.

DXP CONNECTIONS

This system uses the same 6 pin modular connection for Caller ID as the 16x32 DSU above. Refer to fig. A3.

Appendix B - RS232 Pin Outs

When the serial port is configured to “No Flow Control,” only **Transmit** and **Ground** connections are required. Pin 7 and Pin 8 need to be connected only if other serial flow control types are selected.

Computer DB9/M Serial Port

Pin 1 (Carrier Detect)
 Pin 2 (Receive)
 Pin 3 (Transmit)
 Pin 4 (Data Term. Ready)
 Pin 5 (Ground)
 Pin 6 (Data Set Ready)
 Pin 7 (Request to Send)
 Pin 8 (Clear to Send)
 Pin 9 (Ring Indicator)

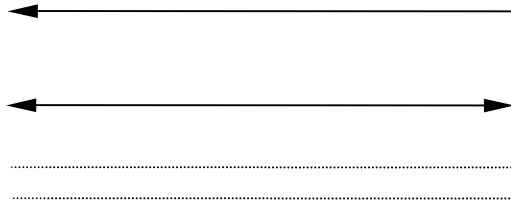

Monitoring Unit DB9/F

Pin 1 (No Connection)
 Pin 2 (Transmit)
 Pin 3 (Receive)
 Pin 4 (No Connection)
 Pin 5 (Ground)
 Pin 6 (Control Line between Units)
 Pin 7 (Internal Connection)
 Pin 8 (Internal Connection)
 Pin 9 (No Connection)

Pin 6 is connected only between multiple Whozz Calling? units and acts as a control line. When units are not transmitting data this line resides at -9 VDC. Upon transmit, the unit pulls this line to +9 VDC. Other Whozz Calling? units connected will detect this as a busy condition and will not transmit until the line returns to -9 VDC.

If connecting to a 25 pin serial port on the computer, we suggest using a 9 to 25 pin serial adapter. The pin outs on a 25 pin serial port are not the same as a 9 pin port. When the serial port is configured to “No Flow Control”, only **Transmit** and **Ground** connections are required. **Request to Send** and **Clear to Send** connections will need to be connected only if other serial flow control types are selected.

Computer DB25/M Serial Port

Pin 2 (Transmit)
 Pin 3 (Receive)
 Pin 4 (Request to Send)
 Pin 5 (Clear to Send)
 Pin 7 (Ground)

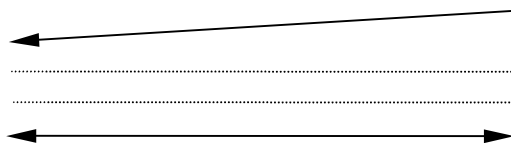

Monitoring Unit DB9/F

Pin 2 (Transmit)
 Pin 3 (Receive)
 Pin 7 (Internal Connection)
 Pin 8 (Internal Connection)
 Pin 5 (Ground)



3107-D Medlock Bridge Road, Norcross, GA 30071 800.240.4637 770.263.7111